

# ASTRONOMICAL ONE-CHANNEL TIME PROGRAMMER ZCM-31, ZCM-31/U

INSTRUCTION MANUAL



Zakład Mechaniki i Elektroniki  
**ZAMEL** sp.j.  
J.W. Dzida, K. Łodzińska

ul. Zielona 27, 43-200 Pszczyna, Poland  
Tel. +48 (32) 210 46 65, Fax +48 (32) 210 80 04  
www.zamelcet.com, e-mail: marketing@zamel.pl



## DESCRIPTION

Digital steering clocks ZCM-31 are intended for realization of time functions in the systems of automatics and steering. Switching on/off the appliance is connected with sunrise and sunset (dawn and dusk). The information about geographic coordinates, the place of the clock's installation, current date and a shift in relation to the universal time- all these factors are used in order to calculate the time of sunrise and sunset. The system calculates the end of civil dusk, that is the phase, during which the centre of the Sun's face is located on the 6 degrees angular below the horizon- the Sun's face is not noticeable but sky is lit with dispersed sunlight. The system additionally has a function of a programmed night break and an ability of shifting the calculated time of sunrise and sunset within a range of +/- 120 min. The construction of a casing makes it possible to install the system on a rail TH 35 and possible sealing the appliance with lead. **The construction of the system guarantees supporting of all the settings with battery energy when the electric power supply is off.**

**CAUTION:** Before installing the device in the switchboard or starting the system operation in order to programme it, the battery security separator should be removed against discharging.

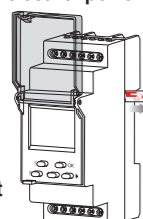

## FEATURES

- Steering dependant on a current hour in an astronomical cycle,
- two-module casing with a protective flap valve,
- steering input IN,
- lighting the LCD display.



The device is designed for single-phase installation and must be installed in accordance with standards valid in a particular country. The device should be connected according to the details included in this operating manual. Installation, connection and control should be carried out by a qualified electrician staff, who act in accordance with the service manual and the device functions. Disassembling of the device is equal with a loss of guarantee and can cause electric shock. Before installation make sure the connection cables are not under voltage. The cruciform head screwdriver 3.5 mm should be used to instal the device. Improper transport, storage, and use of the device influence its wrong functioning. It is not advisable to instal the device in the following cases: if any device part is missing or the device is damaged or deformed. In case of improper functioning of the device contact the producer.

## TECHNICAL DATA

ZCM-31	
Power supply clamps:	A1, A2
Rated voltage:	ZCM-31: 230 V AC (-15 + +10 %) ZCM-31/U: 24 + 250 VAC, 30 + 300 V DC
Rated frequency:	50 / 60 Hz
Rated power consumption:	2 W / 14 VA
Number of channels:	1
Programme:	astronomical
Mode of work:	manual, automatic
Change of season summer/ winter:	automatic, manual
Colour of LCD panel lighting:	amber
Input:	yes
Accuracy of time measurement:	max. ±1 s / 24 h at temp. 25 °C
Time of clock maintenance:	3 years
Time of programme maintenance:	5 years
Clamps of release system:	IN, IN, IN, IN
Clamps of receiver power supply:	11, 12, 14
Parameters of transmitter contacts:	1NO/NC-16 A/250 V AC1 4000 VA
Number of terminating clamps:	12
Intersection of terminating conductors:	0,2 + 2,50 mm <sup>2</sup>
Temperature of work:	-20 + +60 °C
Position of work:	any
Fixing of casing:	TH 35 rail (PN-EN 60715)
Level of protection of casing:	IP20 (PN-EN 60529)
Protectivity class:	II
Overvoltage category:	II
Level of pollution:	2
Measurements:	two-module (35 mm) 90x35x66 mm
Weight:	0,17 kg
Compatibility with norms:	PN-EN 60730-1; PN-EN 60730-2-7 PN-EN 61000-4-2,3,4,5,6,11

## APPEARANCE

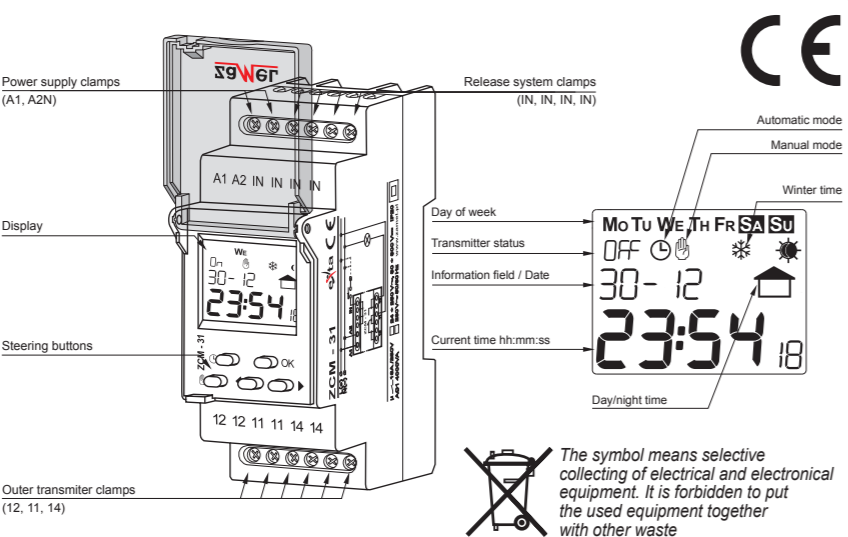

The symbol means selective collecting of electrical and electronic equipment. It is forbidden to put the used equipment together with other waste

## DESCRIPTION

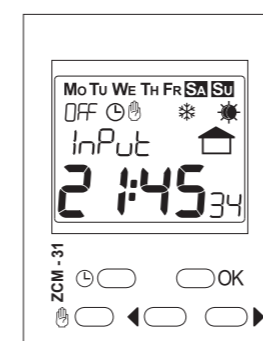

### Description of elements and messages displayed

Mo Tu We Th Fr Sa Su - days of week  
On OFF - transmitter's status  
☉ - automatic mode  
☽ - manual mode  
☼ - winter time  
☀ - summer time  
▶ - external input  
dAtE - day  
SEAR - year  
PRUSE - impulse mode setting  
dELAY - time correction setting  
t, m E - current time setting and summer/winter time shift  
dRtE - current date setting  
Coord - geographical position setting  
InPut - external input setting  
Sr ISE / S SET - sunrise time / sunset time  
LAT: It / LonG - latitude/ longitude  
Auto - automatic, USER - user  
On OFF - on/off

### Buttons descriptions

- ☉ In the main window - entry to automatic mode or change of the transmitter status, if the clock is already in the automatic mode;
- ☽ In other windows - one level up exit without saving the introduced data;
- ☼ In the main window - entry to manual mode or change of transmitter status if the clock is already in the manual mode;
- ☀ In other windows- one level up exit without saving the introduced data;
- OK In the main window - entry to main menu;
- ◀ ▶ In other windows - entry to sub- menu or confirmation of the parameter being set;
- ◀ ▶ Shifting windows /menu options or increasing/ decreasing of the parameter being set;
- Right cursor in the main window- displaying a time of sunrise and sunset.

## MAIN MENU

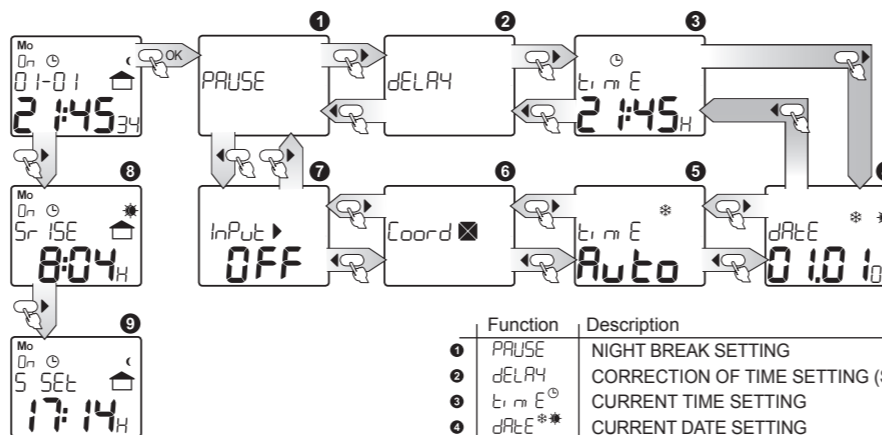

We enter menu from the main window by choosing OK; we move inside menu using cursors ◀ ▶. Return to the main window is possible after pressing button ☉ or ☽. You can enter the windows of displaying calculated sunrise/sunset time from the main window by using cursor ▶. Return is automatic after 10 s.

Function	Description
☼ PAUSE	NIGHT BREAK SETTING
☼ dELAY	CORRECTION OF TIME SETTING (SUNRISE/ SUNSET TIME)
☼ t, m E	CURRENT TIME SETTING
☼ dRtE	CURRENT DATE SETTING
☼ t, m E	TIME SETTING (SUMMER/WINTER SEASON)
☼ Coord	GEOGRAPHICAL POSITION AND TIME ZONE SETTING
☼ InPut	EXTERNAL INPUT SETTING
☼ Sr ISE	CALCULATED SUNRISE TIME
☼ S SET	CALCULATED SUNSET TIME

## DATE SETTING

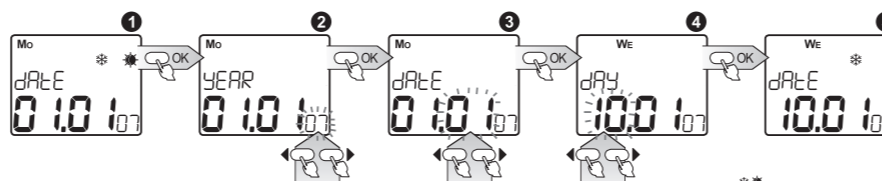

- ☼ dRtE - Current date setting; entry after pressing OK;
- ☼ YEAR - choose adequate year with cursors ◀ ▶ confirm with OK, range of years: 2000+2099;
- ☼ MONTH - choose month with cursors ◀ ▶ confirm with OK;
- ☼ DAY - choose day with cursors ◀ ▶ confirm with OK; the system has a protection against introducing incorrect parameter of a day for a given month ( it takes into account leap years and it automatically calculates the day of the week on the basis of an arranged date);
- ☼ Confirmation causes movement to a date setting window and set-up of current summer/ winter time - if the option Auto is arranged.

It is possible to exit every sub- menu window in any moment without saving settings by pressing the button ☉ or ☽.

## TIME SETTING

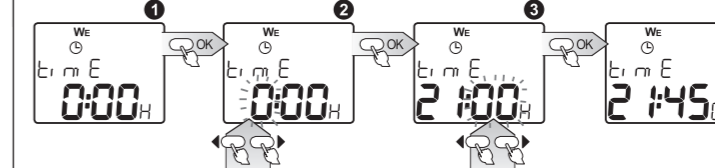

- ☼ t, m E - setting the current clock time; entry after pressing OK;
- ☼ HOUR- choose adequate hour with cursor ◀ ▶ which you can set in 1-24 H or 1-12 A (AM) and 1-12 P (PM)format; confirm with OK;
- ☼ MINUTES - choose adequate parameter of minutes with cursors ◀ ▶ confirm with OK;
- ☼ Confirmation of the parameter of minutes causes simultaneous nullification of the parameter of seconds and movement to the window of time setting.

It is possible to exit every sub- menu window in any moment without saving settings by pressing the button ☉ or ☽.

## WINTER / SUMMER TIME SETTING

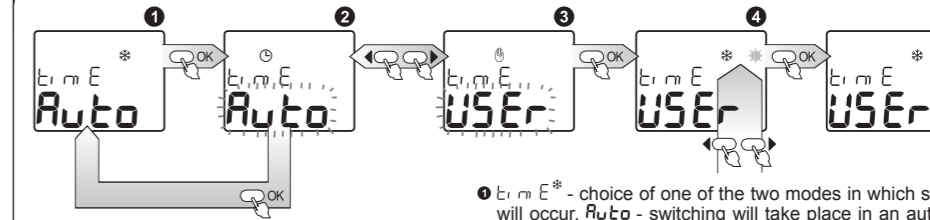

- ☼ t, m E - choice of one of the two modes in which switching between winter and summer season time will occur. Auto - switching will take place in an automatic way, on the last Sunday of March, at 2.00 (for summer time) and on the last Sunday of October, at 3.00 (for winter time), USER - a user chooses between winter/ summer time, entry after pressing OK;
- ☼ setting the mode - choose mode Auto or USER with cursors ◀ ▶, confirm with OK; after choosing the mode Auto, the clock automatically sets the time as winter or summer one, depending on the arranged date; after choosing the mode USER you go to another window;
- ☼ Choose time for winter/ summer one with cursors ◀ ▶ where \* is winter time and ☼ is summer time, if change of marker has happened the system will change the current time by adding or subtracting 1 hour, confirm the operation with OK;
- ☼ After choosing the system moves to winter/ summer time shift window.

## CHANGE OF MODE OF WORK (AUTOMATIC, MANUAL)

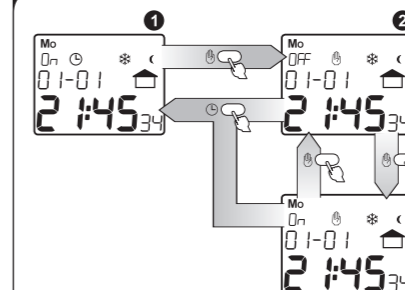

- ☼ CHANGE OF MODE INTO MANUAL - if the system is situated in the main window and it is in the automatic mode, pressing the button ☽ will cause a shift of the system from the manual mode with simultaneous change of transmitter status;
- ☼ Subsequent pressing of button ☽ will cause switching transmitter to the opposite status without change of work mode;
- ☼ CHANGE OF MODE INTO AUTOMATIC - if the system is placed in the main menu and it is in the manual mode, pressing button ☉ will cause automatic shift to the automatic mode, with simultaneous updating transmitter status.

## EXTERNAL INPUT SETTING

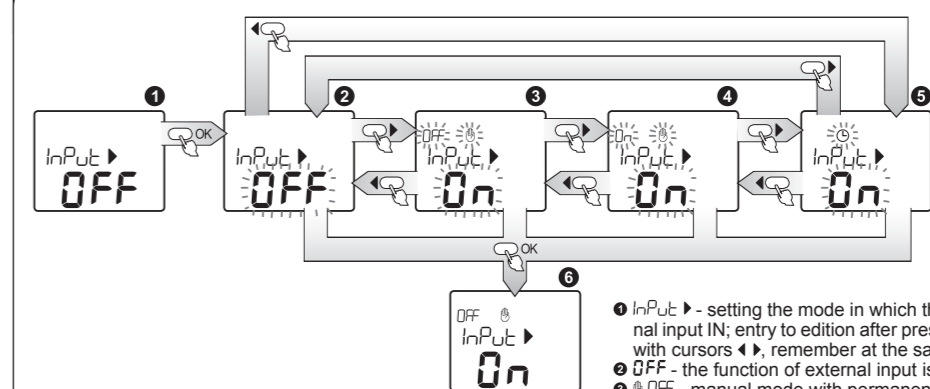

- ☼ InPut - setting the mode in which the system should operate after releasing the external input IN; entry to edition after pressing OK, choose adequate mode for external input with cursors ◀ ▶, remember at the same time that:
- ☼ OFF - the function of external input is switched off;
- ☼ OFF - manual mode with permanent switching the transmitter off;
- ☼ On - manual mode with permanent switching the transmitter on;
- ☼ ☉ - automatic mode, the system switches the transmitter on/ off according to the arranged programmes;
- ☼ Confirm with OK the choice of a given mode; confirmation will cause a movement to the settings window of the external input.

It is possible to exit every sub- menu window in any moment without saving settings by pressing the button ☉ or ☽.

## TIME CORRECTION SETTING

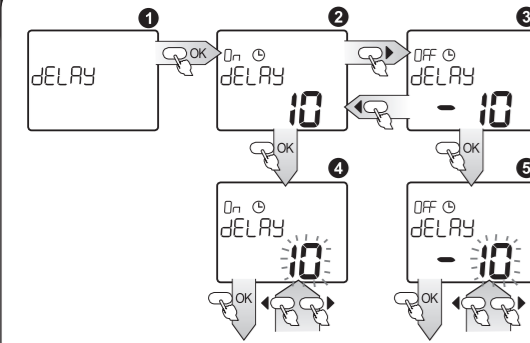

- dDELAY** - setting the time correction; entry to review of settings after pressing OK; Choose time which you should change with cursors **◀▶**, remember at the same time that:
- ① Correction of dusk time; press OK, in order to move to edition;
  - ② Correction of dawn time; press OK, in order to move to edition;
  - ③ Correct the time within a range of -120 + 120 min.; choose an adequate parameter with cursors **◀▶**, confirm the choice with OK.

It is possible to exit every sub-menu window in any moment without saving settings by pressing the button **⊕** or **⊖**.

## NIGHT BREAK SETTING

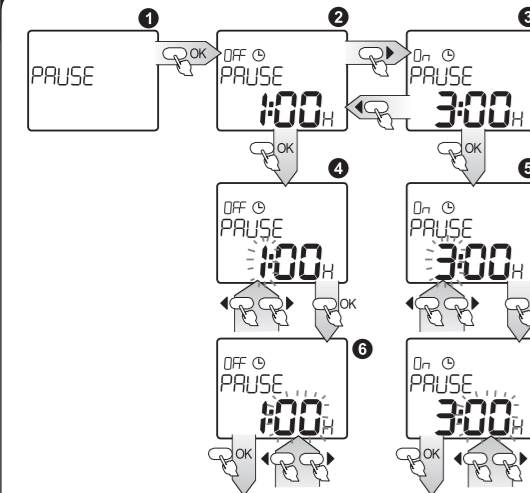

- PAUSE** - setting the duration time of a night break; entry to reviewing the settings after pressing OK; Choose time which you should change with cursors **◀▶**, remember at the same time that:
- ① Time of commencement of a night break; press OK in order to move to edition;
  - ② Time of ending of a night break; press OK in order to move to edition;
  - ③ Choose adequate hour with cursors **◀▶**, confirm the choice with OK;
  - ④ Choose adequate minute with cursors **◀▶**, confirm the choice with OK;

**ATTENTION!!!**  
The clock will work without a night break, if the times of night break beginning and ending are the same.

It is possible to exit every sub-menu window in any moment without saving settings by pressing the button **⊕** or **⊖**.

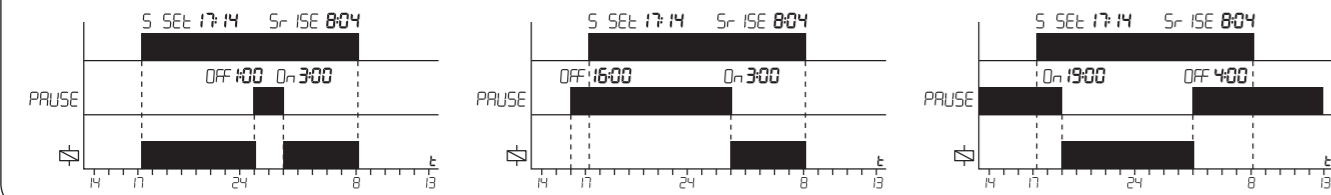

## GEOGRAPHICAL POSITION SETTING

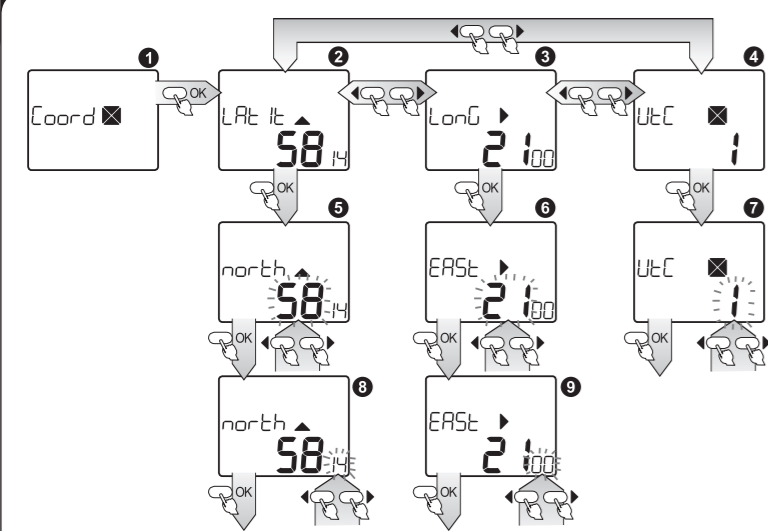

- Coord** - setting longitude, latitude and a time zone; entry to reviewing and edition of settings after pressing OK; choose parameters which should be changed with cursors **◀▶** remember at the same time that:
- ① Lat - latitude;
  - ② Lon - longitude;
  - ③ Utc - time zone in relation to UTC time;

For window **②** (latitude); press OK, so as to move to edition:  
 ④ Choose latitude parameters (degrees) with cursors **◀▶** (within range 90 South + 90 North); confirm with OK;  
 ⑤ Choose latitude minutes with cursors **◀▶** (if in the step ④ 90 latitude was chosen, this step is omitted).

For window **③** (longitude); press OK, in order to move to edition:  
 ④ Choose longitude degrees with cursors **◀▶** (within range 180 West + 180 East); confirm the choice with OK.  
 ⑤ Choose longitude minutes with cursors **◀▶** (if in the step ④ longitude was chosen, this step is omitted).

For window **④** (time zone); press OK, so as to move to edition:  
 ④ Choose hour shift of time zone with cursors **◀▶** (within a range -12 + 12); confirm your choice with OK.

It is possible to exit every sub-menu window in any moment without saving settings by pressing the button **⊕** or **⊖**.

## GEOGRAPHICAL POSITION OF GREATER TOWNS AND CITIES IN POLAND

1. Bełchatów	51° 22' N	19° 22' E	55. Ostrołęka	53° 04' N	21° 34' E
2. Będzin	50° 20' N	19° 07' E	56. Ostrowiec Świętokrzyski	50° 56' N	21° 24' E
3. Białą Podlaska	52° 02' N	23° 07' E	57. Ostrow Wielkopolski	51° 39' N	17° 42' E
4. Białystok	53° 07' N	23° 10' E	58. Pabianice	51° 39' N	19° 23' E
5. Bielsko-Biała	49° 50' N	19° 04' E	59. Piekary Śląskie	50° 23' N	18° 57' E
6. Bydgoszcz	53° 07' N	18° 00' E	60. Piła	53° 09' N	16° 44' E
7. Bytom	50° 23' N	18° 54' E	61. Piotrków Trybunalski	51° 24' N	19° 41' E
8. Chełm	51° 09' N	23° 29' E	62. Płock	52° 33' N	19° 42' E
9. Chorzów	50° 18' N	18° 57' E	63. Poznań	52° 24' N	16° 54' E
10. Ciechanów	52° 52' N	20° 38' E	64. Pruszków	52° 10' N	20° 48' E
11. Częstochowa	50° 48' N	19° 07' E	65. Przemyśl	49° 47' N	22° 46' E
12. Dąbrowa Górnicza	50° 19' N	19° 16' E	66. Puławy	51° 25' N	21° 58' E
13. Dębica	50° 03' N	21° 25' E	67. Racibórz	50° 05' N	18° 14' E
14. Elbląg	54° 06' N	19° 24' E	68. Radom	51° 24' N	21° 10' E
15. Elk	53° 49' N	22° 21' E	69. Radomsko	51° 04' N	19° 27' E
16. Gdańsk	54° 22' N	18° 38' E	70. Ruda Śląska	50° 16' N	18° 42' E
17. Gdynia	54° 30' N	18° 32' E	71. Rybnik	50° 05' N	18° 33' E
18. Gliwice	50° 17' N	18° 40' E	72. Rzeszów	50° 01' N	22° 00' E
19. Głogów	51° 39' N	16° 05' E	73. Sanok	49° 33' N	22° 13' E
20. Gniezno	52° 32' N	17° 36' E	74. Siedlce	52° 10' N	22° 16' E
21. Gorzów Wielkopolski	52° 44' N	15° 15' E	75. Siemianowice Śląskie	50° 18' N	19° 01' E
22. Grudziądz	53° 30' N	18° 47' E	76. Sieradz	51° 36' N	18° 45' E
23. Hrubieszów	50° 49' N	23° 53' E	77. Skarżysko-Kamienna	51° 07' N	20° 55' E
24. Iława	53° 36' N	19° 34' E	78. Skieniewice	51° 57' N	20° 08' E
25. Inowrocław	52° 40' N	18° 16' E	79. Słupsk	54° 28' N	17° 02' E
26. Jarosław	50° 01' N	22° 41' E	80. Sosnowiec	50° 19' N	19° 10' E
27. Jastrzębie-Zdrój	49° 57' N	18° 35' E	81. Stalowa Wola	50° 35' N	22° 03' E
28. Jaworzno	50° 08' N	19° 16' E	82. Starachowice	51° 03' N	21° 04' E
29. Jelenia Góra	50° 54' N	15° 44' E	83. Stargard Szczeciński	53° 20' N	15° 02' E
30. Kalisz	51° 45' N	18° 05' E	84. Starogard Gdański	53° 58' N	18° 32' E
31. Katowice	50° 15' N	19° 00' E	85. Suwałki	54° 05' N	22° 56' E
32. Kędzierzyn-Koźle	50° 20' N	18° 12' E	86. Szczecin	53° 25' N	14° 25' E
33. Kielce	50° 53' N	20° 37' E	87. Świdnica	50° 51' N	16° 25' E
34. Kłodzko	50° 26' N	16° 40' E	88. Świętochłowice	50° 17' N	18° 54' E
35. Kolobrzeg	54° 10' N	15° 34' E	89. Tarnobrzeg	50° 35' N	21° 41' E
36. Konin	52° 13' N	18° 16' E	90. Tarnowskie Góry	50° 27' N	18° 52' E
37. Koszalin	54° 11' N	16° 11' E	91. Tarnów	50° 02' N	21° 00' E
38. Kraków	50° 04' N	19° 56' E	92. Tczew	54° 06' N	18° 43' E
39. Krosno	49° 41' N	21° 45' E	93. Tomaszów Mazowiecki	51° 31' N	20° 01' E
40. Kutno	52° 14' N	19° 22' E	94. Toruń	53° 02' N	18° 37' E
41. Legionowo	52° 24' N	20° 57' E	95. Tychy	50° 08' N	18° 59' E
42. Legnica	51° 13' N	16° 10' E	96. Wałbrzych	50° 47' N	16° 17' E
43. Leszno	51° 51' N	16° 34' E	97. Warszawa	52° 14' N	21° 00' E
44. Łębork	54° 33' N	17° 45' E	98. Wejherowo	54° 36' N	18° 15' E
45. Lubin	51° 24' N	16° 12' E	99. Władysławowo	54° 50' N	18° 19' E
46. Lublin	51° 14' N	22° 34' E	100. Włocławek	52° 39' N	19° 03' E
47. Łomża	53° 10' N	22° 05' E	101. Wodzisław Śląski	50° 00' N	18° 27' E
48. Łódź	51° 47' N	19° 28' E	102. Wrocław	51° 07' N	17° 02' E
49. Mielec	50° 17' N	21° 26' E	103. Zabrze	50° 18' N	18° 47' E
50. Mysłowice	50° 14' N	19° 08' E	104. Zamość	50° 43' N	23° 16' E
51. Nowy Sącz	49° 37' N	20° 42' E	105. Zawiercie	50° 30' N	19° 25' E
52. Nysa	50° 28' N	17° 20' E	106. Zgierz	51° 51' N	19° 25' E
53. Olsztyn	53° 47' N	20° 30' E	107. Zielona Góra	51° 56' N	15° 30' E
54. Opole	50° 40' N	17° 56' E	108. Żory	50° 03' N	18° 42' E

## ASSEMBLY

- Disconnect power supply circuit with a fuse, electrical energy redundant switch or insulation switch (all of them connected to adequate circuit)
- Check non-voltage status on power supply conductors, with an appropriate tool
- Assemble the appliance ZCM-31 in the switching station on the TH 35 rail.
- Connect conductors under clamps according to the connection scheme

## INTERNAL SCHEME

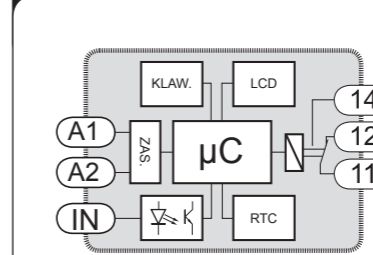

## CASING MEASUREMENTS

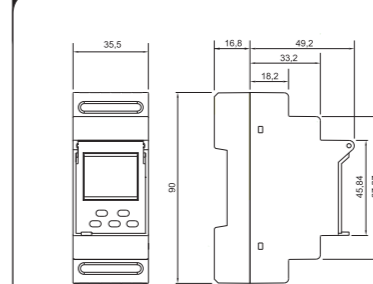

## PRODUCT FAMILY

ZCM-31 Programmer belongs to ZCM family of products.

### ZCM-xx/U

Power supply:	ZCM-xx - 230 V~
	ZCM-xx/U - 24 + 250 V~
	30 + 300 V~
Programmer type:	11 - week (1 channel)
	12 - week (2 channel)
	21 - year
	31 - astronomical
Device type	

## WARRANTY CARD

There is 24 months guarantee on the product

Salesman stamp and signature, date of sale

## CONNECTION

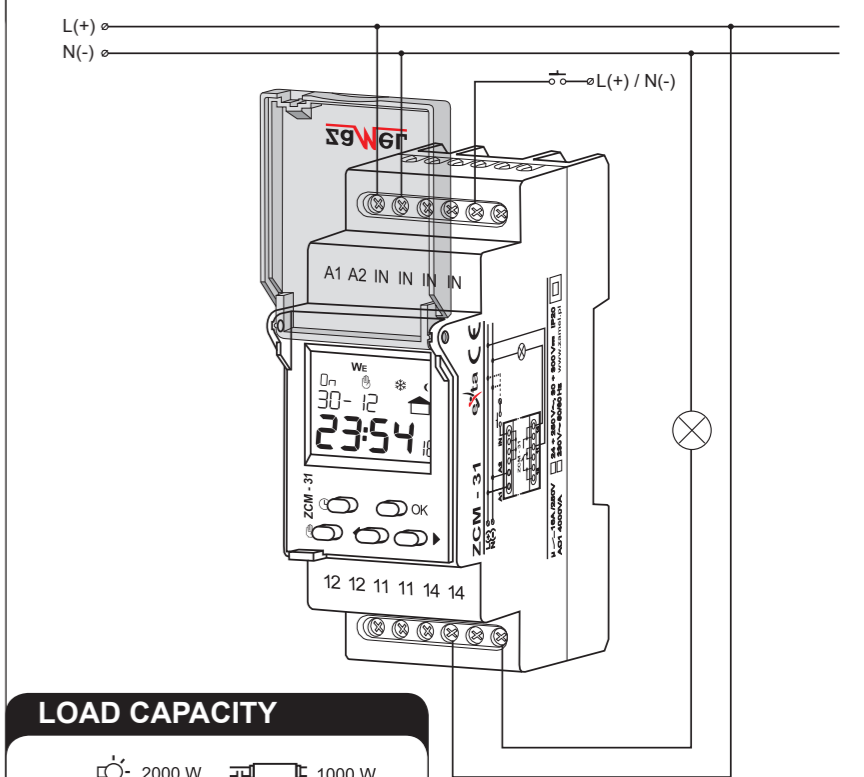

## LOAD CAPACITY



## ADVANTAGES



**Intelligent calendar** - the system has an in-built calendar, which automatically takes into account leap years, it makes introducing non-existent date impossible, and also calculates a day of a week on the grounds of a date and it takes into account the change of time into winter/ summer one.

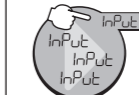

**Universal external input** - the system has an external input, with the help of which a user can enforce change of clock work mode without the necessity of interfering in a switchboard but using e. g. remote controller button.

## MAIN RESET

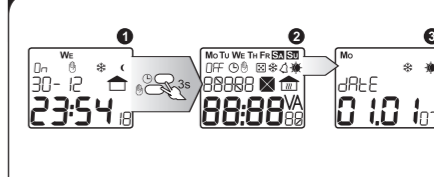

- ① In order to cancel the clock system (time, date, activity of given functions etc.) you should hold buttons **⊕** and **⊖** simultaneously in the main menu for **3 sec**;
- ② All the display fields will light up;
- ③ After a while, the clock will automatically set date and time.

Attention: In order to restore factory settings, you should additionally hold button OK

- ZMIE ZAMEL SP. J. assures 24 months guarantee for the product.
- The manufacturer's guarantee does not cover any of the following actions:
  - mechanical damage during transport, loading / unloading or under other circumstances,
  - damage caused by incorrect product mounting or misuse,
  - damage caused by unauthorised modifications made by the PURCHASER or any third parties to the product or any other devices needed for the product functioning,
  - damage caused by Act of God or any other incidents independent of the manufacturer.
- The PURCHASER shall lay any claims in writing to the dealer or ZMIE ZAMEL SP. J.
- ZMIE ZAMEL SP. J. is liable for processing any claim according to current Polish legislation.
- ZMIE ZAMEL SP. J. shall process the claim at its own discretion: product repair, replacement or money return.
- The manufacturer's guarantee is valid in the Republic of Poland.
- The PURCHASER's statutory rights in any applicable legislation whether against the retailer arising from the purchase contract or otherwise are not affected by this warranty.