

UPM304

DIN 96x96 Compact LED Power Meter



- Depth 60mm Only
- True RMS Measurement
- More than 60 Electrical Parameters Displayed
- Neutral Current Monitoring
- Bi-Directional, Four Quadrants Values on Serial Communication Port
- High Contrast Bright LED Display
- Power and Current Demand Calculation During User-Definable Time Period
- THD Calculation on Voltage and Current
- No PTs Required up to 600 (750)V_{AC}
- Programmable CT and PT Ratios
- User Friendly



General Description

The UPM304 is a digital meter able to measure the electrical parameters on three-phase systems.

It provides accurate measurements even by distorted waveform.

Three high brightness LED displays ensure maximum visibility even in difficult environment lighting condition.

The working parameters can be easily set up by instrument keypad.

The RS232 or RS485 serial communication port allows to transfer the three-phase electrical parameters from the instrument.

The WINTOOL software, available for free on the Internet, allows to show on a PC all the measured values and to do setting faster.

The UPM304 replaces multiple analog meters as well as single function meters such as voltmeters, ammeters, wattmeters, varmeters, frequency-meters, powerfactor-meters, energy-meters, etc.

The UPM304 is a compact, cost effective meter operating both as a stand-alone device or as an integral part of a more extensive energy monitoring and management network.

See the UPM303 / UPM304 and UPM305 comparison table on page 4

Benefits

- The UPM304 is the low cost solution for monitoring of all the main electrical parameters.
- It provides peak average current and power demand information. This data is essential to work out proper strategies aimed at avoiding uncontrolled power peaks and consequent penalties.
- The UPM304 being ultra-compact and easy to mount is suitable for replacing conventional meters. The UPM304 provides powerful capabilities not offered by traditional analog meters.
- The UPM304 allows time and cost saving on mounting, compared to many individual single-function instruments.
- Via communication port it is possible to read and log on a PC all the readings. The remote connection allows to generate on a PC consumption profiles, logged values trends, cost allocation and reports as well as to identify critical values.

Applications

- Switchboards, gensets, motor control centers, etc.
- Power monitoring & control systems
- Individual machine load monitoring
- Demand management
- Remote metering and cost allocation

Main Features

Measurements

- Three-phase 3-wire or 4-wire unbalanced load operation.
- True RMS metering provides accurate measurement even for distorted waveform.
- Fully bi-directional four-quadrant values both on serial communication port and display.
- More than 60 electrical parameters measured (instantaneous, demand, peak values, energies, etc.).
- THD calculation on voltage and current.
- Direct measurement up to 600 (750) V_{AC} .
- Programmable 1A / 5A current full scale.
- Programmable CT & PT ratios.
- Optional temperature indication.

Front Panel Display

- High contrast bright, easy to read, LED display.
- Up to three parameters displayed on the same page, with four digits plus sign digit.
- Password protection for setup and reset.

Communication

- RS232 or RS485 optoisolated communication port.
- Modbus protocol or Standard ASCII protocol.
- Communication speed programmable up to 57600 bps.
- Optional built-in Profibus, Lonbus, Ethernet interfaces.

Inputs & Outputs

- Two digital outputs for energy pulsing or for alarm tripping.
- Optional one digital input for tariff sincronization.

Other

- Optional internal interface for Rogowski transducer. Available range 200, 1000 or 3000A on request.

INSTANTANEOUS MEASUREMENTS			DISPLAY	COMM
PHASE VOLTAGE	$V_{L1-N} - V_{L2-N} - V_{L3-N}$ [V]	●	●	
LINE VOLTAGE	$V_{L1-L2} - V_{L2-L3} - V_{L3-L1}$ [V]	●	●	
SYSTEM VOLTAGE	V [V]		●	
LINE CURRENT	$I_{L1} - I_{L2} - I_{L3} - I_N$ [A]	■	■	
SYSTEM CURRENT	I [A]		■	
NEUTRAL CURRENT	I_N [A]	■	■	
POWER FACTOR	$PF_{L1} - PF_{L2} - PF_{L3}$	●	●	
SYSTEM POWER FACTOR	PF		●	
APPARENT POWER	$S_{L1} - S_{L2} - S_{L3}$ [VA]	■	■	
SYSTEM APPARENT POWER	S [VA]	■	■	
ACTIVE POWER	$P_{L1} - P_{L2} - P_{L3}$ [W]	■	■	
SYSTEM ACTIVE POWER	P [W]	■	■	
REACTIVE POWER	$Q_{L1} - Q_{L2} - Q_{L3}$ [var]	■	■	
SYSTEM REACTIVE POWER	Q [var]	■	■	
FREQUENCY	f [Hz]	●	●	
DEMAND (AVERAGE VALUES)	$3 \times I_{AVG} - S_{AVG} - P_{AVG}$	■	■	
VOLTAGE THD	$THD_{L1} - THD_{L2} - THD_{L3}$ [%]	○	○	
CURRENT THD	$THD_{L1} - THD_{L2} - THD_{L3}$ [%]	○	○	
PHASE REVERSAL	123 / 132	●	●	
TEMPERATURE	T [°C, °F]	○	○	
TIME COUNTER	Elapsed Time [Hours]	○	○	
STORED DATA				
SYSTEM ACTIVE ENERGY	[Wh]	●	■	
SYSTEM APPARENT ENERGY	[VAh]	●	■	
SYSTEM LAGGING REACTIVE ENERGY	[varh ind]	●	■	
SYSTEM LEADING REACTIVE ENERGY	[varh cap]	●	■	
H/L TARIFF REGISTERS	[Wh, VAh, varh]	○	○	
PEAK VALUES	$3 \times V_{L-N} - 3 \times V_{L-L} - 3 \times I_L - 3 \times I_{AVG} - I_N - P_{AVG} - S_{AVG}$	●	●	
● = Standard ■ = Bi-directional value ○ = Optional DISPLAY = shown on the display COMM = on communication port				

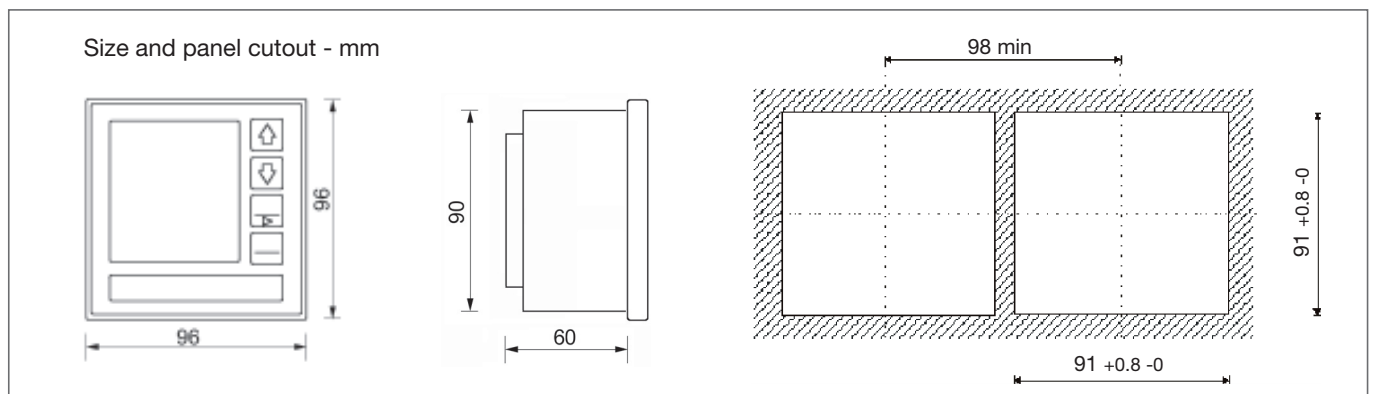

Specifications

Power supply

Rated voltage: 230 V_{AC} (or 115 V_{AC} on request) +15% -20%
 Consumption: 2VA max

Voltage inputs

Maximum measurable voltage: 600 (750)V_{AC} max L-L
 Input impedance: >1.3 MΩ
 Burden: max 0.15 VA per phase
 Frequency: 45 - 65 Hz

Current inputs

Rated current (I_b): 1 / 5 A_{RMS} programmable
 Min / max measurable current: 20 mA / 7 A_{RMS}
 Maximum overload: 10A_{RMS} continuous - 100 A_{RMS} for 1 sec.
 Input impedance: 0.02 Ω approximately
 Burden: max 0,5 VA per phase
 Insulation voltage: 150 V_{AC} max between phases

Typical accuracy

Voltage: ± 0.2% reading ± 0.1% full scale
 Current: ± 0.2% reading ± 0.1% full scale
 Active power: ± 1% reading ± 0.2% full scale (PF=1)
 Power factor: ±1% reading (0.5 inductive - 0.8 capacitive)
 Active energy: ±1% reading (0.5 inductive - 0.8 capacitive)
 Frequency: ± 0.05% reading ± 1 digit from 45 to 65 Hz

Display and operating controls

Display: high brightness 14 mm LED display
 three lines, four digits (eight for energies)
 Keypad: 4 push-buttons

Communication port

Type: RS232 or RS485 on request, optoisolated
 Baud Rate: 300 to 57600 Baud

Digital outputs

Type: no.2 optoisolated (50V-100mA_{DC})

Digital input

Type: no.1 optoisolated (19÷130V_{AC-DC})

Environmental conditions

Operating temperature: from -15°C to +60°C
 Storage temperature: from -30°C to +75°C
 Relative humidity: 80% max. without condensation

Mechanical characteristics

Material: plastic enclosure
 Protection degree: IP54 (front panel); IP20 (terminals)
 Terminals: conductors 2.5mm²
 Size / Weight: 96 x 96 x 60 mm or 96 x 96 x 105 mm
 500 gr max, depending on the configuration

Standards compliance

Safety: 73/23/EEC and 93/68/EEC directives,
 EN61010.1 safety standard
 EMC: 89/366/EEC directive and following
 modifications 93/31/EEC and 93/68/EEC,
 EN50081-2, EN50082-2, EN61326/A1

TYPICAL WIRING DIAGRAMS

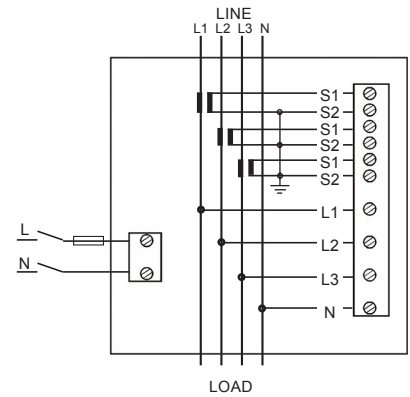

3-Phase 4-Wire up to 600V

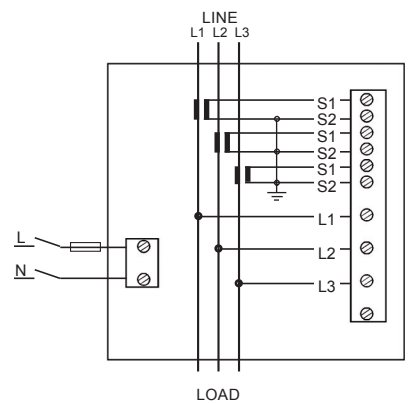

3-Phase 3-Wire up to 600V
 For two CTs only, see the diagram below

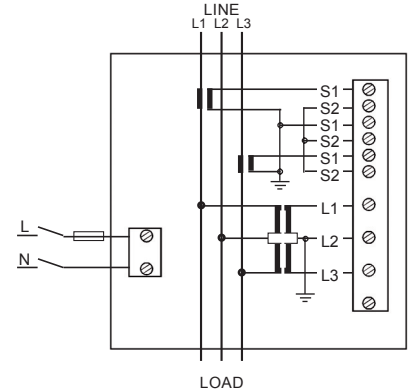

3-Phase 3-Wire above 600V

Instruments Comparison Table			
	UPM303	UPM304	UPM305
DISPLAY	3x4 digits	3x4 digits	3x4 digits
MEASURED PARAMETERS (ON DISPLAY) (1)	31	56	62
MEASURED PARAMETERS (ON SERIAL PORT) (2)	33	59	65
NEUTRAL CURRENT CALCULATION	●	●	
VOLTAGE AND CURRENT THD	●		
DEMAND AND PEAK DEMAND	●	●	
PHASE REVERSAL	●	●	
ENERGY COUNTERS	8 digits	8 digits	
H/L TARIFF REGISTERS	○	○	
DIGITAL OUTPUTS	alarm	alarm+pulse	alarm+pulse
WIRING MODES	2	2	2
1 / 5 A PROGRAMMABLE CT INPUTS	●	●	

(1) = Mono-directional values ● = Standard
 (2) = Bi-directional values ○ = Optional

Measuring Units Indication

The measuring units are indicated by the display, that switches from the measured value to the units.
 The advantage is a very good visibility in all light conditions even if the instrument is far away.
 The display exchange can be made every 10 seconds automatically or pressing the ? key on the instrument keypad.
 The drawings below show some examples.

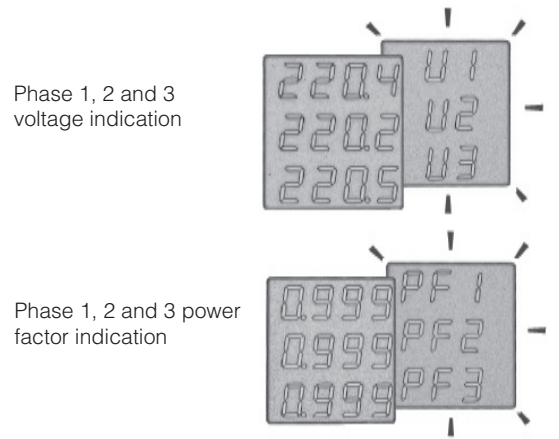

WINTOOL - Communication and Monitoring Software

- For Microsoft Windows environment
- User-friendly
- Real-time Data Viewing
- Quick Instruments Setup
- Parameters verification
- Available for free on the Web

WINTOOL software enables the power meters to be connected to a PC for measured data viewing.
 It allows an easy and fast way to set the instrument parameters by a desktop or portable PC.
 The remote monitoring is carried out through serial communication port (RS232 or RS485) or Ethernet TCP/IP/Internet connection.
 It is a multilanguage software, at present the available languages are: English, German, Italian, French, Spanish, Hungarian.

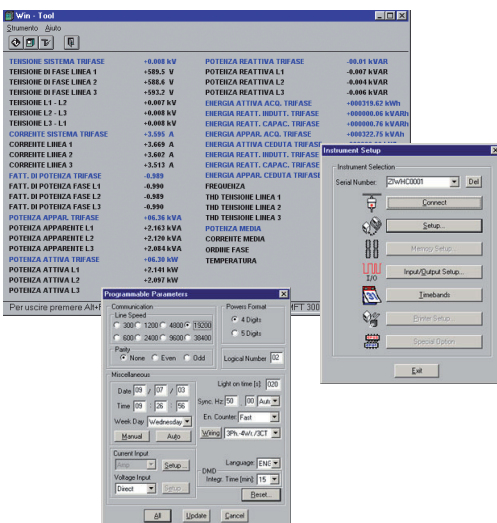

It is the "free-of-charge" solution to configure and display the readings from instruments with or without display.

Real-time Data Viewing

WINTOOL displays real-time values from the instruments.

The available information includes:

- Real time values (voltage, current, power, PF, power)
- Energy consumption values (active, reactive and apparent)

Quick instrument Setup

Because of a user-friendly approach, the power meter can be configured more quickly by the WINTOOL software than by using keypad.

The software shows the hardware configuration of the connected meter.

A SEARCH function allows to automatically detect the connected meter without the need of writing the serial number.

DOWNLOAD IT FROM OUR WEB SITE

ORDERING INFORMATION

ALF A [] [] [] [] X [] X [] X X []

UPM304

Series

Manual Language

- D = German
- I = Italian
- U = English

Communication Protocol

- X = None (without serial port)
- B = ASCII Standard
- C = MODBUS
- L = LON - Lonbus interface (2)
- P = PROFIBUS - Profibus interface (2)
- E = ETH - Ethernet interface (2)

Aux Power Supply

- A = $115V_{AC} +15\% -20\%$
- B = $230V_{AC} +15\% -20\%$
- C = $65 \div 250V_{AC} / 90 \div 250V_{DC}$ (3)
- R = $19 \div 60V_{DC}$ (3)

Serial Port

- X = None
- 2 = RS232
- 5 = RS485

Memory

- X = None

Firmware Options

- X = None
- 5 = THD - on voltage and current

Hardware Options

- X = None

Other

- X = None
- P = RGW - Rogowski inputs 200A
- R = RGW - Rogowski inputs 1000A
- S = RGW - Rogowski inputs 3000A
- C = RGW - Rogowski inputs (customized val.)
- T = Temperature sensor

Inputs

- X = None

Analog Outputs

- X = None

Digital Outputs

- 2 = Basic version with No.2 on-board optoisolated outputs NPN type
- 3 = Basic version with No.2 on-board optoisolated outputs PNP type

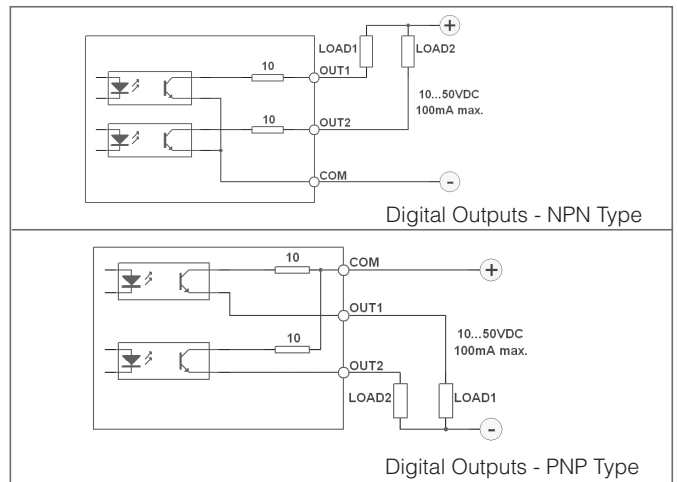

NOTES

(1) The basic instrument configuration includes:

- Power Supply $230V_{AC}$ (or $115V_{AC}$) $+15\% -20\%$
- No. 2 Optoisolated Outputs ($50V - 100mA_{DC}$)

(2) This communication interface modifies the following features of the instrument:

- The depth increases from 60mm to about 100mm.
- The range of the power supply becomes $65 \div 250V_{AC} / 90 \div 250V_{DC}$ (or $19 \div 60V_{DC}$ on request).

(3) Selecting this option the depth of the instrument increases from 60mm to about 100mm.

Subject to change without notice



INNOVATIVE ELECTRONIC SYSTEMS

ALGODUE ELETRONICA s.r.l.
Via Passerina, 3/A
28010 FONTANETO D'AGOGNA
(NO) ITALY

Tel: +39 0322 89864 - 89307
Fax: +39 0322 89871
E-mail: info@algodue.com
Website: www.algodue.com

