

D-SUB connector set - VS-25-SET-STD - 1652198

Please be informed that the data shown in this PDF Document is generated from our Online Catalog. Please find the complete data in the user's documentation. Our General Terms of Use for Downloads are valid (<http://phoenixcontact.com/download>)



D-SUB connector set, shell size 3, unshielded

The illustration shows the product version VS-09-SET-STD



Key Commercial Data

Packing unit	1 pc
GTIN	 4 017918 917135
Weight per Piece (excluding packing)	69.6 g
Custom tariff number	85366990
Country of origin	Germany
Note	Made to Order (non-returnable)

Technical data

General data

Number of positions	25
Signal type/category	Universal
Degree of pollution	2

Standards and Regulations

Flammability rating according to UL 94	V0
----------------------------------------	----

Classifications

eCl@ss

eCl@ss 4.0	27140816
eCl@ss 4.1	27260701
eCl@ss 5.0	27260701
eCl@ss 5.1	27260701
eCl@ss 6.0	27260705

D-SUB connector set - VS-25-SET-STD - 1652198

Classifications

eCl@ss

eCl@ss 7.0	27440309
eCl@ss 8.0	27440302

ETIM

ETIM 2.0	EC001121
ETIM 3.0	EC001132
ETIM 4.0	EC001132
ETIM 5.0	EC001132

UNSPSC

UNSPSC 6.01	31261501
UNSPSC 7.0901	31261501
UNSPSC 11	31261501
UNSPSC 12.01	31261501
UNSPSC 13.2	31261501

Approvals

Approvals

Approvals

EAC

Ex Approvals

Approvals submitted

Approval details

EAC

Drawings

D-SUB connector set - VS-25-SET-STD - 1652198

Dimensional drawing

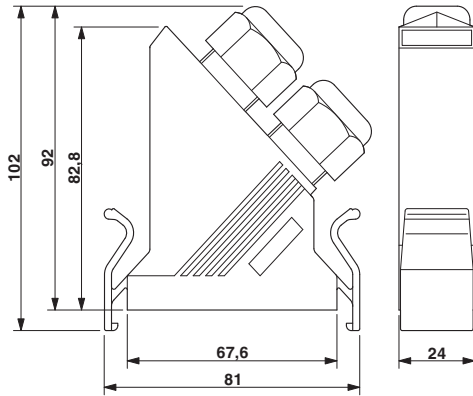

Dimensional drawing

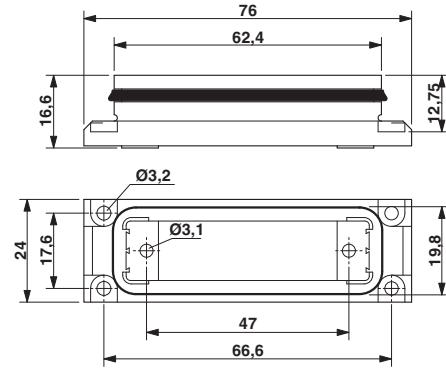

D-SUB panel mounting frame

Dimensional drawing

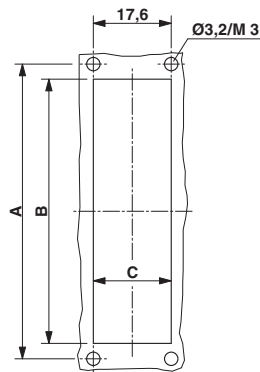

Panel cutout