

D-SUB connector set - VS-15-SET-EMV - 1689132

Please be informed that the data shown in this PDF Document is generated from our Online Catalog. Please find the complete data in the user's documentation. Our General Terms of Use for Downloads are valid (<http://phoenixcontact.com/download>)



D-SUB connector set, shell size 2, IP67 protection, with shrouds

The illustration shows the version VS-09-SET-EMV



Key Commercial Data

Packing unit	1 pc
GTIN	 4 017918 877996
Weight per Piece (excluding packing)	79.4 g
Custom tariff number	85366990
Country of origin	Germany

Technical data

General data

Number of positions	15
Signal type/category	Universal
Degree of pollution	2

Standards and Regulations

Flammability rating according to UL 94	V0
--	----

Classifications

eCl@ss

eCl@ss 4.0	27140816
eCl@ss 4.1	27260701
eCl@ss 5.0	27260701
eCl@ss 5.1	27260701
eCl@ss 6.0	27261203
eCl@ss 7.0	27440202

D-SUB connector set - VS-15-SET-EMV - 1689132

Classifications

eCl@ss

eCl@ss 8.0	27440302
------------	----------

ETIM

ETIM 2.0	EC000437
ETIM 3.0	EC000437
ETIM 4.0	EC001132
ETIM 5.0	EC001132

UNSPSC

UNSPSC 6.01	31261501
UNSPSC 7.0901	31261501
UNSPSC 11	31261501
UNSPSC 12.01	31261501
UNSPSC 13.2	31261501

Approvals

Approvals

Approvals

EAC / EAC

Ex Approvals

Approvals submitted

Approval details

EAC

EAC

Drawings

D-SUB connector set - VS-15-SET-EMV - 1689132

Dimensional drawing

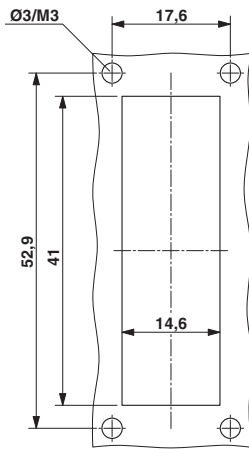

Dimensional drawing

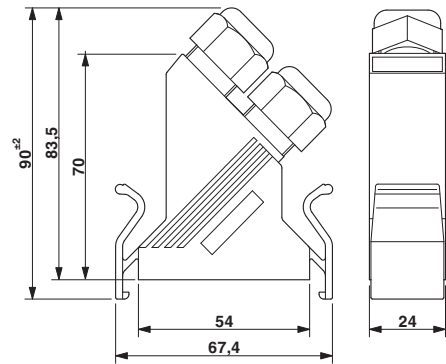

D-SUB sleeve housings

Panel cutout

Dimensional drawing

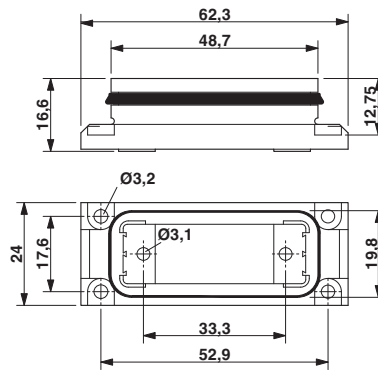

D-SUB panel mounting frame