

Ninigi

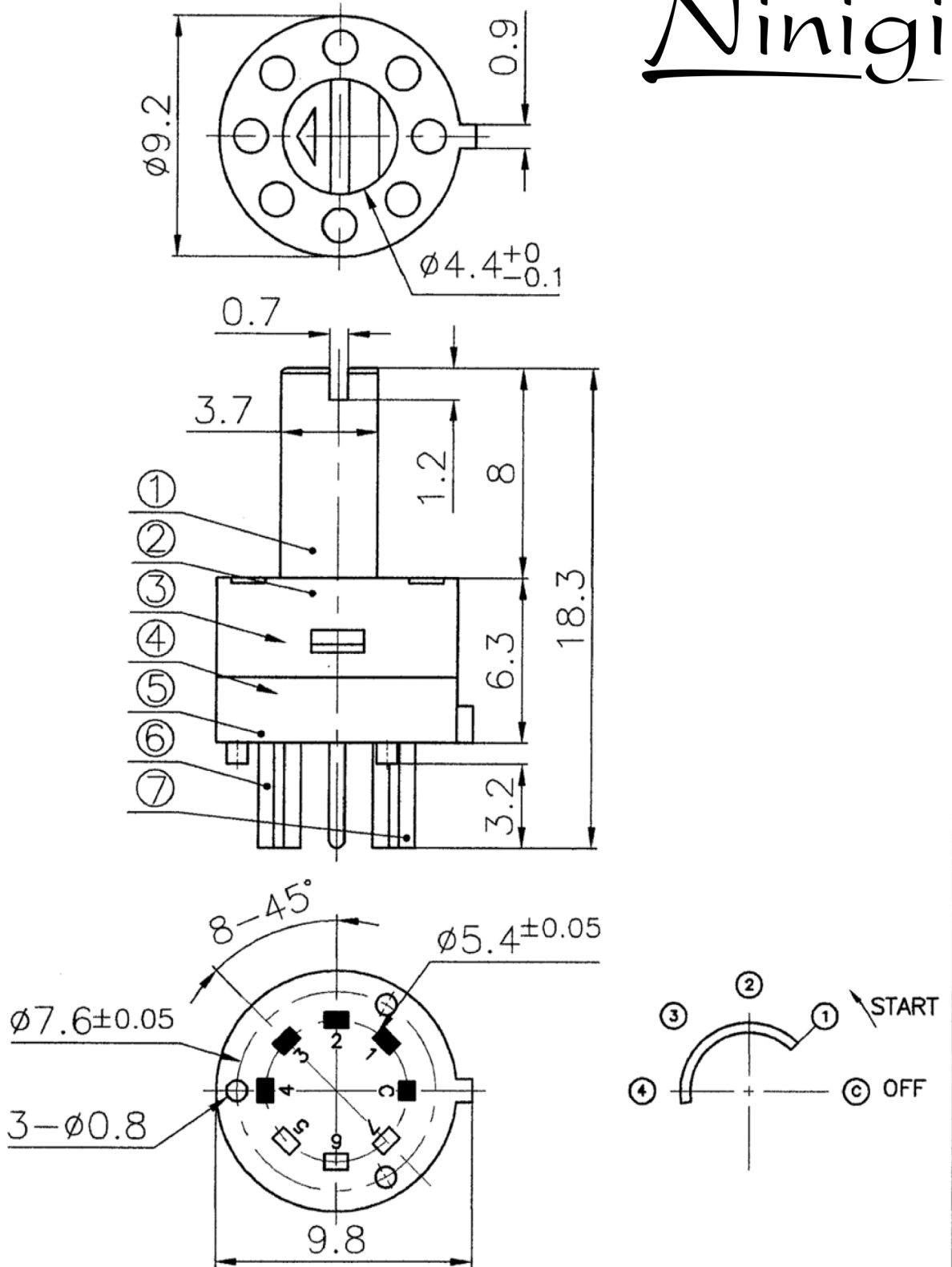

7	SR09205M	Internal terminal	1	Brass	Sliver Plating				
6	SR09205N	External terminal	4	Brass	Sliver Plating				
5	SR0911	Basic	1	PA66+15%GF	No Plating				
4	SR0906	Contact Plate	1	Phosphor Bronze	Sliver Plating				
3	SR0915	Spring	1	SWPA	Tin Plating				
2	SR0909	Case	1	PBT	No Plating				
1	SR0901- FS	Shaft	1	PA66+15%GF	No Plating				
						1	Jul,16'13		
NO	Part No	Description	QTY	Material	Finishing	MODEL	SR09-1-4-8FS-N		B
TOLERANCES		DIMENSION	SCALE	DRAWING BY	CHECKED BY	APPROVED BY	DRAWING NO		
less than	10	± 0.3	m/m	/			SR09-004		
above	10 - 30	± 0.5							
above	30 -100	± 1.0							
angular dimension		$\pm 5^\circ$							
							Slide\SR09\Spec		