

| | | |
|-------------------|----------------------------------|--|
| U.I. Lapp GmbH | PRODUCT INFORMATION |  |
| | SKINDICHT® MR-M hexagonal | 14.11.2013 |

Enables the use of cable glands with smaller connection threads than the existing threaded holes
 With guide notch for O-ring
 Assembling with a wrench



Space requirement

Application range

Machines
 Devices
 Housings

Design

Metric connection thread acc. to EN 50262

Remark

Viton® is a registered trademark of DuPont de Nemours

Photographs are not to scale and do not represent detailed images of the respective products.

Technical Data

On request:

VITON® O-ring
 -20 °C to +200 °C

Material:

Body: nickel-plated brass
 O-ring: NBR

Temperature range:

-30 °C to +100 °C



| | | |
|--------------------|------------------------------|-------|
| Product Management | Document: LAPP_PRO1034EN.pdf | 1 / 3 |
|--------------------|------------------------------|-------|

SKINDICHT® MR-M hexagonal

14.11.2013

| Part number | Thread/ male M1 | Thread/ female M2 | SW (mm) | ØA [mm] | Overall length/ C (mm) | Thread length/ D (mm) | Outer Ø (mm) | Pieces / PU |
|--|-----------------|-------------------|---------|---------|------------------------|-----------------------|--------------|-------------|
| SKINDICHT® MR-M hexagon | | | | | | | | |
| 52101965 | 16 x 1.5 | 12 x 1.5 | 18 | 20,2 | 8,5 | 5.5 | | 50 |
| 52101966 | 20 x 1.5 | 16 x 1.5 | 22 | 24,4 | 9.0 | 6.0 | | 50 |
| 52101967 | 25 x 1.5 | 16 x 1.5 | 28 | 31,2 | 10.0 | 6.5 | | 50 |
| 52101968 | 25 x 1.5 | 20 x 1.5 | 28 | 31,2 | 10.0 | 6.5 | | 50 |
| 52101969 | 32 x 1.5 | 16 x 1.5 | 36 | 40.0 | 11,5 | 8.0 | | 25 |
| 52101972 | 32 x 1.5 | 20 x 1.5 | 36 | 40.0 | 11,5 | 8.0 | | 25 |
| 52101973 | 32 x 1.5 | 25 x 1.5 | 36 | 40.0 | 11,5 | 8.0 | | 25 |
| 52101974 | 40 x 1.5 | 25 x 1.5 | 43 | 47,5 | 12,5 | 8.5 | | 10 |
| 52101975 | 40 x 1.5 | 32 x 1.5 | 43 | 47,5 | 12,5 | 8.5 | | 10 |
| 52101976 | 50 x 1.5 | 40 x 1.5 | 54 | 58.0 | 14.0 | 10.0 | | 5 |
| 52101977 | 63 x 1.5 | 50 x 1.5 | 67 | 74.0 | 14.0 | 9.5 | | 5 |
| 52101979 | 75 x 1.5 | 63 x 1.5 | 80 | 90.0 | 17.0 | 11.0 | | 1 |
| SKINDICHT® MR-M, blank brass, with hexagon | | | | | | | | |
| 52006572 | 80 x 2 | 63 x 1.5 | 85 | | 23.0 | 15.0 | 93,5 | 1 |

| | | |
|-------------------|----------------------------------|--|
| U.I. Lapp GmbH | PRODUCT INFORMATION |  LAPP GROUP |
| | SKINDICHT® MR-M hexagonal | 14.11.2013 |

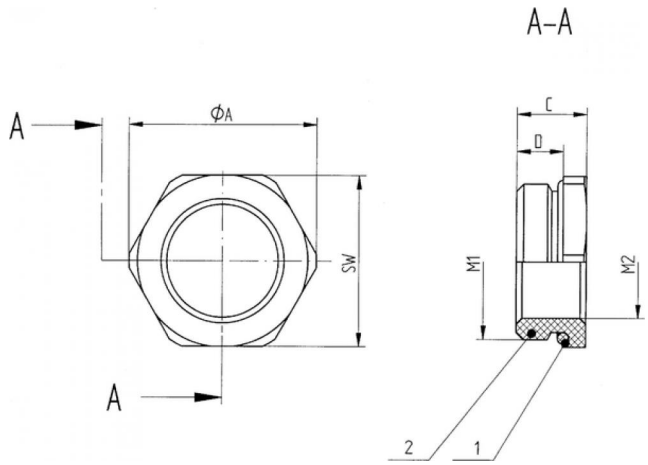

| | | |
|--------------------|------------------------------|-------|
| Product Management | Document: LAPP_PRO1034EN.pdf | 3 / 3 |
|--------------------|------------------------------|-------|