

■Features

- Intelligent reverse connect protection, the power supply reverse connection does not damage the IC.
- The control circuit and the LED share the only power source.
- Control circuit and RGB chip are integrated in a package of 5050 components, form a complete control of pixel point.
- Built-in signal reshaping circuit, after wave reshaping to the next driver, ensure wave-form distortion not accumulate.
- Built-in electric reset circuit and power lost reset circuit.
- Each pixel of the three primary color can achieve 256 brightness display, completed 16777216 color full color display, and scan frequency not less than 400Hz/s.
- Cascading port transmission signal by single line.
- Any two point the distance more than 5m transmission signal without any increase circuit.
- When the refresh rate is 30fps, cascade number are not less than 1024 points.
- Send data at speeds of 800Kbps.
- The color of the light were highly consistent, cost-effective..

■Outline Dimension

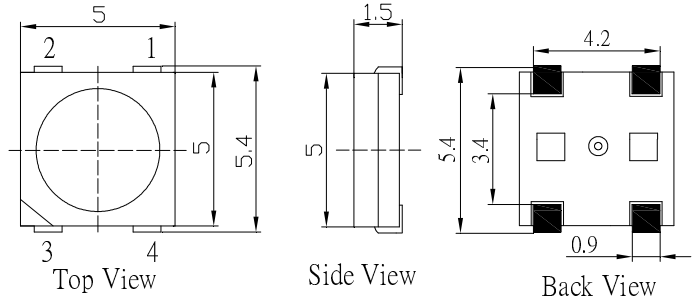

NO.	Symbol	Function description
1	VDD	Power supply LED
2	DOUT	Control data signal output
3	VSS	Ground
4	DIN	Control data signal input

Unit:mm
Tolerance:±0.20mm

■Applications

- LED decorative lighting, Indoor/outdoor LED video irregular screen
- Full-color module, Full color soft lights a lamp strip.

■Absolute Maximum Rating

(Ta=25°C)

Item	Symbol	Value	Unit
Power Supply Voltage	V _{DD}	+3.5~+5.3	V
Input Voltage	V _I	-0.5~V _{DD} +0.5	V
Operation Junction Temperature	T _{opt}	-25~+80	°C
Storage Temperature	T _{stg}	-40 ~ +105	°C
Lead Soldering Temperature	T _{sol}	260°C/5sec	-

■Directivity

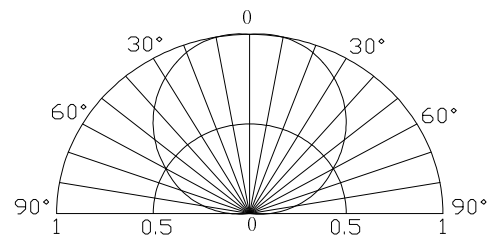

■Electrical Characteristics (Ta=20~+70°C, VDD=4.5~5.5V, VSS=0V unless otherwise specified)

Item	Symbol	Condition	Min.	Typ.	Max.	Unit
Input current	I _I	V _I =V _{DD} /V	-	-	±1	μA
Input voltage level	V _{IH}	D _{IN} , SET	0.7V _{DD}	-	-	V
	V _{IL}	D _{IN} , SET	-	-	0.3 V _{DD}	
Hysteresis voltage	V _H	D _{IN} , SET	-	0.35	-	

■ **Switching Characteristics** ($T_A=-20\sim+70^{\circ}\text{C}$, $V_{DD}=4.5\sim 5.5\text{V}$, $V_{SS}=0\text{V}$, unless otherwise specified)

Parameter	Symbol	Condition	Min	Typ	Max	Unit
Operation frequency	F_{osc2}	—	—	800	—	KHz
Transmission delay time	t_{PLZ}	CL=15pF, DIN→DOUT, RL=10KΩ	—	—	300	ns
Fall time	t_{THZ}	CL=300pF, OUTR/OUTG/OUTB	—	—	120	μs
Data transmission rate	F_{MAX}	Duty ratio 50%	400	—	—	Kbps
Input capacity	C_I	—	—	—	15	pF

■ **LED Characteristic Parameter**

Emitting Color	Wavelength (nm)	Luminous Intensity (mcd)	Voltage (V)
Red	620-625	390-420	2.0-2.2
Green	520-525	660-720	3.0-3.4
Blue	465-470	180-200	3.0-3.4

■ **Data Transfer Time** ($T_H+T_L=1.25\mu\text{s}\pm 150\text{ns}$)

T0H	0 code ,high voltage time	0.35us	±150ns
T1H	1 code ,high voltage time	0.9us	±150ns
T0L	0 code , low voltage time	0.9us	±150ns
T1L	1 code ,low voltage time	0.35us	±150ns
RES	low voltage time	Above 50μs	

■ **Sequence Chart:**

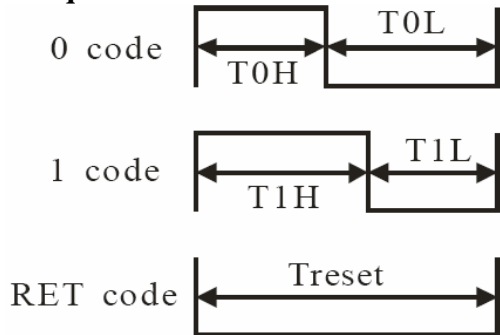

■ **Cascade Method:**

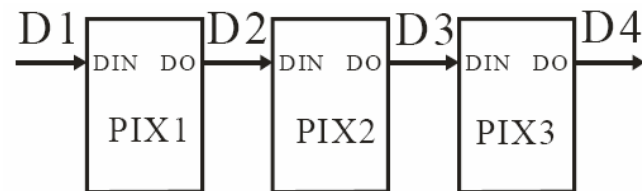

■Data Transmission Method:

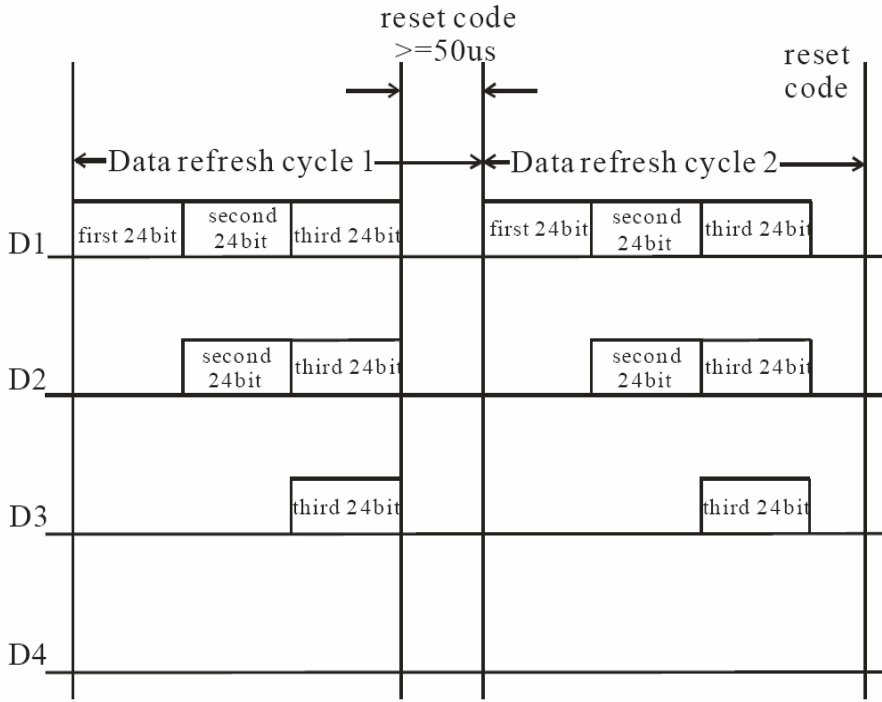

Note: The data of D1 is sent by MCU, and D2, D3, D4 through pixel internal reshaping amplification to transmit.

■Composition of 24bit data:

G7	G6	G5	G4	G3	G2	G1	G0	R7	R6	R5	R4	R3	R2	R1	R0	B7	B6	B5	B4	B3	B2	B1	B0
----	----	----	----	----	----	----	----	----	----	----	----	----	----	----	----	----	----	----	----	----	----	----	----

Note: Follow the order of GRB to send data and the high bit sent at first.

■Typical Application Circuit:

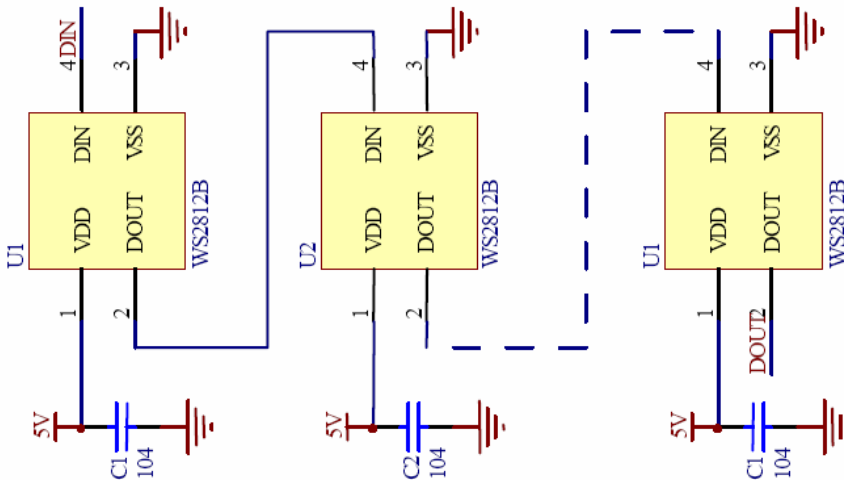

■ General Description

OSTW5050C1A is a intelligent control LED light source that the control circuit and RGB chip are integrated in a package of 5050 components. It internal include intelligent digital port data latch and signal reshaping amplification drive circuit.

Also include a precision internal oscillator and a 12V voltage programmable constant current control part, effectively ensuring the pixel point light color height consistent.

The data transfer protocol use single NZR communication mode. After the pixel power-on reset, the DIN port receive data from controller, the first pixel collect initial 24bit data then sent to the internal data latch, the other data which reshaping by the internal signal reshaping amplification circuit sent to the next cascade pixel through the DO port.

After transmission for each pixel, the signal to reduce 24bit. pixel adopt auto reshaping transmit technology, making the pixel cascade number is not limited the signal transmission, only depend on the speed of signal transmission. LED with low driving voltage, environmental protection and energy saving, high brightness, scattering angle is large, good consistency, low power, long life and other advantages.

The control chip integrated in LED above becoming more simple circuit, small volume, convenient installation.

■ Storage

· Storage Conditions

Before opening the package:

The LEDs should be kept at 30°C or less and 60%RH or less. The LEDs should be used within a year. When storing the LEDs, moisture proof packaging with absorbent material (silica gel) is recommended.

· After opening the package:

Soldering should be done right after opening the package (within 24hrs).

Keeping of a fraction, sealing and Temperature: 5~40°C Humidity: Less than 30%.

If the package has been opened more than 1 week or the color of desiccant changes, components should be dried for 10-12hrs, at 60±3°C.

· Optosupply LED electrode sections are comprised of a silver plated copper alloy. The silver surface may be affected by environments which contain corrosive gases and so on. Please avoid conditions which may cause the LED to corrode, tarnish or discolor. This corrosion or discoloration may cause difficulty during soldering operations. It is recommended that the User use the LEDs as soon as possible.

· Please avoid rapid transitions in ambient temperature, especially in high humidity environments where condensation can occur.

■ Soldering Heat Reliability:

Reflow soldering Profile

· Reflow soldering should not be done more than two times.

· When soldering, do not put stress on the LEDs during heating.

· After soldering, do not warp the circuit board.

· Repairing should not be done after the LEDs have been soldered. When repairing is unavoidable, a double-head soldering iron should be used. It should be confirmed beforehand whether the

Characteristics of the LEDs will or will not be damaged by repairing.

Solder=Low Lead Free
Average ramp-up rate = 3°C/sec. max.
Preheat temperature: 160°~200°C
Preheat time = 120 sec. max.
Ramp-down rate = 6°C/sec. max.
Peak temperature = 245°C max.
Time within 3°C of actual peak temperature = 25 sec. max.
Duration above 220°C is 40 sec. max.

