

GN 322.3

Spoked handwheels with fold-away handle

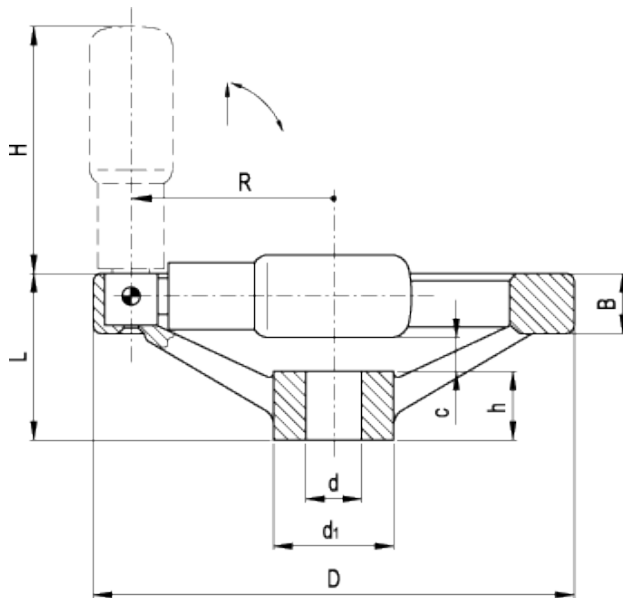

technical informations

Material

Aluminium, fine sandblasted matte surface, turned and mirror-polished rim.

Assembly

- Version B: H7 reamed hole.
 - Version K: H7 reamed hole and keyway in compliance with [DIN 6885/1 P9 tolerance](#).
- For fixing GN 322.3 on shafts by a grub screw see [Technical Data](#).

Fold-away handle

Type GN 798.3 polyamide based (PA) technopolymer, black colour, matte finish. Resistant to solvents, oils, greases and other chemical agents. The two-volume special design of the handle provides the operator's hand with a safe and ergonomic grip when turning the handwheel.

Accessories on request

Axial retaining washer type [GN 184](#).

Technical data

Axial and radial runout lower than 0.4.

Standard Elements	Main dimensions					Bore		Handle			Weight
Description	D	L	B	d ₁	c	d _{H7}	h	H	Ø	R	g
GN 322.3-125-B12-R	125	44	24.5	31	6.5	12	18	61.5	22	50	469
GN 322.3-125-K12-R	125	44	24.5	31	6.5	12	18	61.5	22	50	467
GN 322.3-140-B14-R	140	45.5	24.5	36	6	14	19	76.5	24	57.5	553
GN 322.3-140-K14-R	140	45.5	24.5	36	6	14	19	76.5	24	57.5	551
GN 322.3-160-B14-R	160	47	25	36	6.5	14	20	76.5	24	67.5	697
GN 322.3-160-B16-R	160	47	25	36	6.5	16	20	76.5	24	67.5	693
GN 322.3-160-K14-R	160	47	25	36	6.5	14	20	76.5	24	67.5	695
GN 322.3-160-K16-R	160	47	25	36	6.5	16	20	76.5	24	67.5	691
GN 322.3-200-B18-R	200	52.5	25	42	7.5	18	24	86.5	25	84	978
GN 322.3-200-B20-R	200	52.5	25	42	7.5	20	24	86.5	25	84	973
GN 322.3-200-K18-R	200	52.5	25	42	7.5	18	24	86.5	25	84	975
GN 322.3-200-K20-R	200	52.5	25	42	7.5	20	24	86.5	25	84	970
GN 322.3-250-B22-R	250	61	26.5	48	12	22	28	86.5	25	111	1388
GN 322.3-250-K22-R	250	61	26.5	48	12	22	28	86.5	25	111	1384



ELESA and GANTER models all rights reserved in accordance with the law. Always mention the source when reproducing our drawings.

STANDARD MACHINE ELEMENTS WORLDWIDE