

SECTION A-A

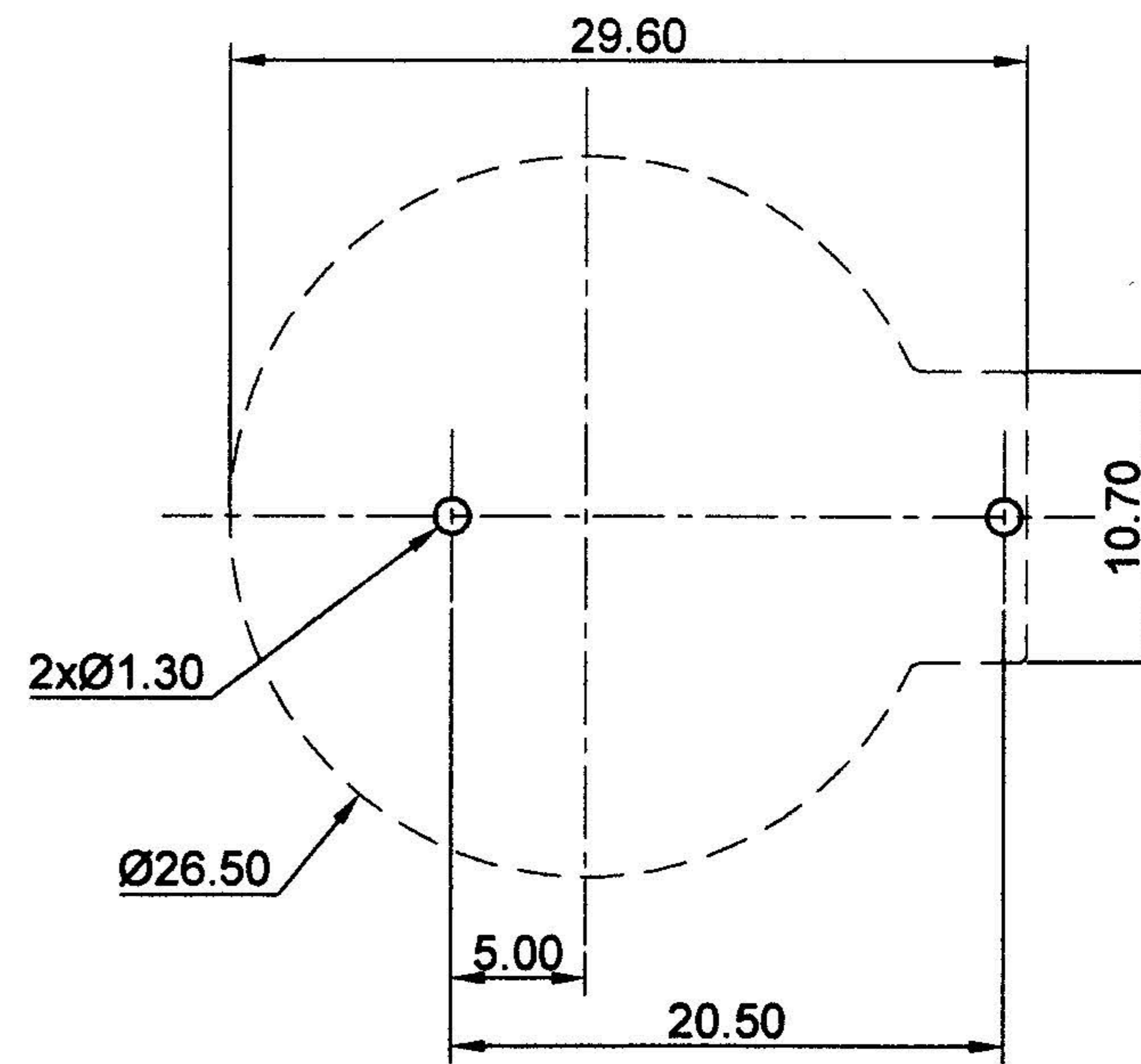

PCB MOUNTING LAYOUT

SPECIFICATION

- (1) ITEM NO. : CH031-2477LF
- (2) HOUSING MATERIAL: PBT UL94V0, BLACK COLOR
- (3) CONTACT 1 MATERIAL: 0.3MM THICK PHOSPHOR BRONZES NICKEL PLATED  
CONTACT 2 MATERIAL: 0.4MM THICK PHOSPHOR BRONZES NICKEL PLATED
- (4) CURRENT RATING : 0.5A (AC/DC)
- (5) VOLTAGE RATING : 500V (AC/DC)
- (6) CONTACT RESISTANCE: 30 MILLIOHMS
- (7) INSULATION RESISTANCE: 1000 MEGAOHMS
- (8) TEMPERATURE RANGE: -55° C TO +85° C
- (9) HUMIDITY: 40° C AND 90-95% RH FOR 96 HOURS
- (10) RoHS COMPLIANT

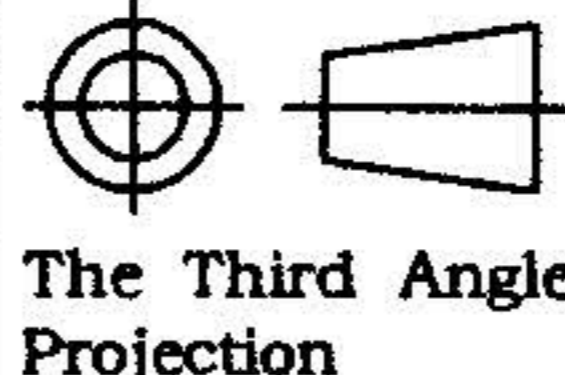
3			<b>COMF COMFORTABLE ELECTRONIC CO.LTD.</b>		
2					
1					
NO.	MODIFICATION	DATE	NAME	COIN CELL HOLDER: CH031-2477LF	
General Tolerances			SCALE	2:1	APPD
0 ~ >3	± 0.10	30 ~ >120	UNIT	MM	CHKD
3 ~ >6	± 0.10	120 ~ >400	MAT'L	SEE SPEC.	DWN
6 ~ >30	± 0.20	Angle: ± 3°	DATE	NOV. 18. 2013	DR NO
 The Third Angle Projection					CH031-1113