

LOC		DIST		P		F		ZONE		LTR		REVISIONS		DATE	APPD	
CM	53												D	REV PER EC 0730-0212-94	11-22-94	JH

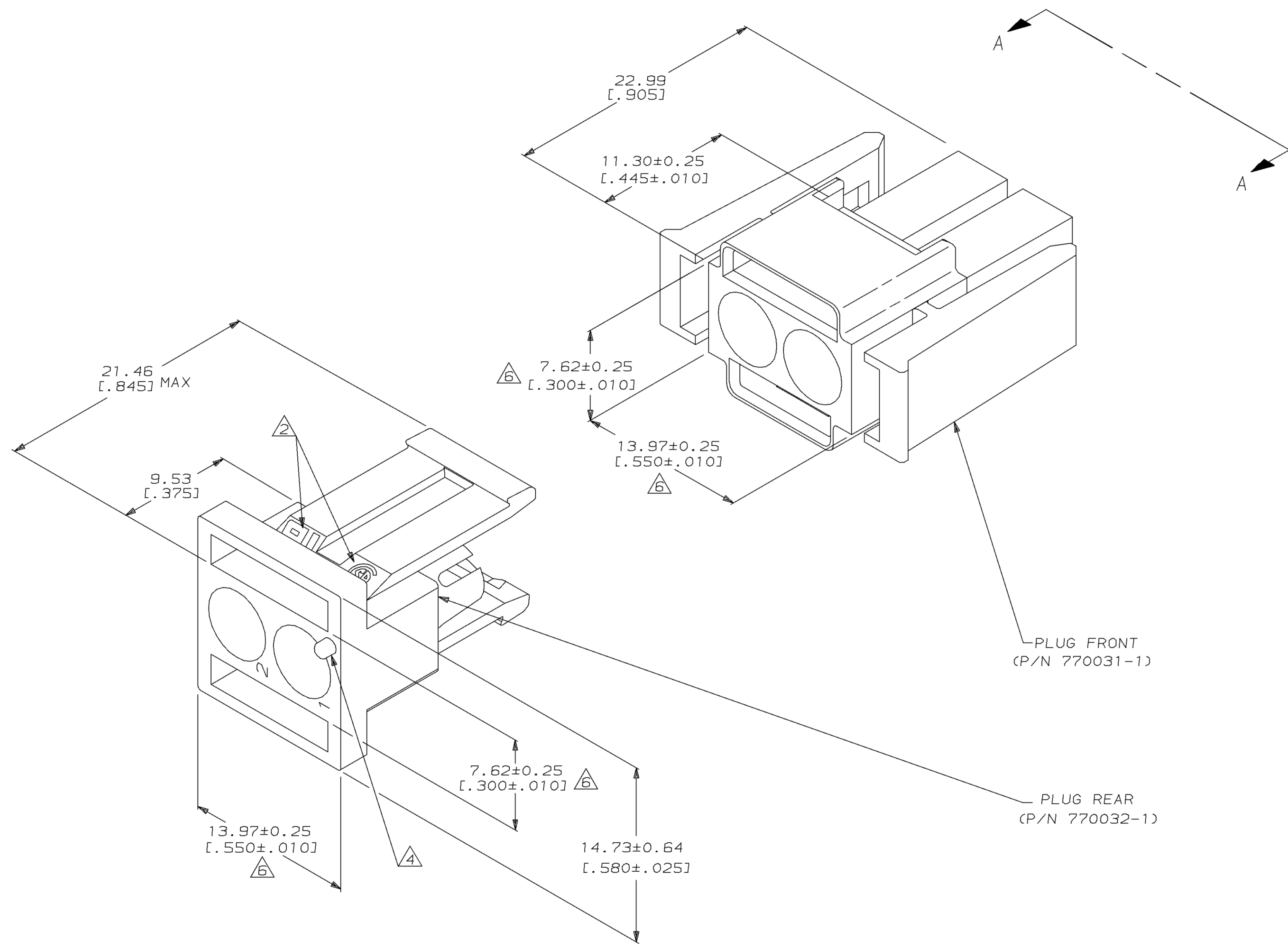

1. BULK PACKAGED, UNASSEMBLED.
2. APPROVAL AGENCY LOGO LOCATED APPROXIMATELY AS SHOWN.
3. AMP LOGO LOCATED THIS SURFACE.
4. CIRCUIT NUMBER ONE IDENTIFICATION BUTTON AND CIRCUIT IDENTIFICATION NUMBERS ARE EACH LOCATED ADJACENT TO THE APPROPRIATE CIRCUIT CAVITIES.
5. NEW MOLD CONSTRUCTION PROVIDES MATERIAL REDUCTION CORING AT BASE OF SILOS WITH NO CORING AS OPTIONAL.
6. DIMENSION INDICATED IS AS MOLDED. ADDITIONAL GROWTH DUE TO SUBSEQUENT MOISTURE ABSORPTION MAY OCCUR.

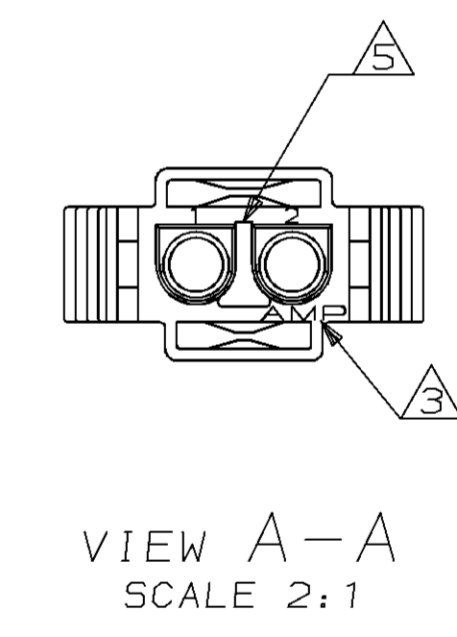

PLUG FRONT
(P/N 770031-1)

PLUG REAR
(P/N 770032-1)

770017-1
PART NUMBER

DO NOT SCALE PRINT. UNLESS SPECIFIED DIMENSIONS IN INCHES TOLERANCES ON:		DR 1-22-92 K. SALMON		AMP INCORPORATED Harrisburg, Pa. 17105	
1 ± .005		CHK 1-22-92 R. SWING		NAME	
2 PLC DEC ± .013 [0.005]		APPD 1-22-92 M. TRULL		PLUG HOUSING KIT, 2 CIRCUIT, IN-LINE, UNIVERSAL MATE-N-LOK™ II	
3 ANGLES ± .005		APPD 1-22-92 M. TRULL		DRAWING NO	
MATERIAL		PRODUCT SPEC		770017	
NYLON, UL94V-0,		APPLICATION SPEC		SCALE	
FINISH		WEIGHT		5:1	
				SHEET 1 OF 1	

